

Ser._Mater._Sci._Eng._1098_02 2023-box-culvert-railway.pdf

by

Submission date: 10-Jul-2021 07:07AM (UTC+0700)

Submission ID: 1617705836

File name: Ser._Mater._Sci._Eng._1098_022023-box-culvert-railway.pdf (748.41K)

Word count: 1824

Character count: 9050

PAPER · OPEN ACCESS

The bending capacity of box culvert for railway tracks

To cite this article: Z Patongloan *et al* 2021 *IOP Conf. Ser.: Mater. Sci. Eng.* **1098** 022023

View the [article online](#) for updates and enhancements.

The bending capacity of box culvert for railway tracks

Z Patongloan^{1*}, R Irmawaty² and A B Muhiddin²

¹ Master Student, Department of Civil Engineering, Hasanuddin University, Jl. Perintis Kemerdekaan KM.10, Kota Makassar, Indonesia

² Assoc Professor, Department of Civil Engineering, Hasanuddin University, Jl. Perintis Kemerdekaan KM.10, Kota Makassar, Indonesia

*zp.unhas.19@gmail.com

Abstract. The Trans-Sulawesi railway is a system of railway that was built to reach important areas on the Sulawesi island. In the construction of the Makassar-Parepare segment II railroad line between Barru-Palanro along a 45 km long many complementary buildings will be built, one of that is 26 underpass units/box culvert. This box culvert was chosen because the area between Makassar to Pare-pare often floods that can make the railway track will be disturbed. In addition, box culvert also functions as a crossing building. This paper aims to evaluate the bending capacity of the box culvert under railway track. Two box culvert precast concrete specimens with dimensions of 2000 mm x 2000 mm x 1000 mm with a wall thickness of 250 mm, and were given a monotonic static load. The bending test results obtained an initial crack load of 102 kN and 119.7 kN on BC-1 and BC-2 specimens, respectively. This initial crack load is greater than the crack load design (Pcrack) which is 76.8 kN. The loading is stopped at a load of 420 kN even though the specimen has not yet reached the ultimate load, due to device limitations. Nevertheless, the maximum load achieved by the two specimens exceeds the design ultimate load (Pult) of 227.2 kN.

1. Introduction

Trains are considered as transportation with special and main characteristics to transport passengers and goods in bulk, save energy, save space use, have a high safety factor, low pollution levels and are more efficient than road transportation. The Trans-Sulawesi railway is a system of railway that was built to reach important areas on the Sulawesi island. The railway system was built starting in 2015, starting from phase I, which is the railway line from Makassar to Parepare, which is 145 km long. The Trans-Sulawesi railway project is targeted to reach a length of 2,000 kilometres from Makassar to Manado [1]. In the construction of the Makassar-Parepare segment II railway line between Barru-Palanro along 45 km, many complementary buildings will be built, one of them is 26 underpasses/ Box Culvert [2]. This Box Culvert was chosen because the area between Makassar to Pare-pare often floods that can make the railway track will be disturbed. In addition, Box Culvert also functions as a crossing building.

Box Culvert is a precast concrete product with a box shape. Generally, it functions as a culvert, this concrete is also one of the types of reinforced concrete. Nowadays, box culvert are made of precast concrete. The main problem in precast concrete design is connection problems. Things that are very important to consider in the selection of precast concrete components are strength, ductility, volume change, durability and fire resistant [3,4].



Content from this work may be used under the terms of the [Creative Commons Attribution 3.0 licence](https://creativecommons.org/licenses/by/3.0/). Any further distribution of this work must maintain attribution to the author(s) and the title of the work, journal citation and DOI.

To get the safety aspect of a railway track, which crosses the Box Culvert, one must meet the standardization of the building crossed by the train [3,4]. Based on the above, it will be discussed the analysis of bending capacity of Box Culvert under railway tracks.

2. Experimental program

Laboratory studies were carried out to know the quality of box culvert 2000 x 2000 x 1000 mm type, thus it can be known if box culvert technically can operate and meet the design specification.

2.1. Specimens

The specimens consisted of 2 Box Culvert (BC) 2000 x 2000 x 1000 mm type, taken randomly from a series of products made from the same materials and methods, as shown in Figure 1. The box culvert technical specifications are as follows:

- Material:
 - Concrete = 35 MPa
 - Steel rebar D 13, 16 and 19 mm (UTS = 7850 kg/m³, fy = 390 MPa, fu = 560 MPa).
- Design parameters:
 - Axle Load = 25 tons
- Design load:
 - Initial crack load = 76.8 kN
 - Initial crack moment = 24 kN.m
 - Ultimate load = 227.2 kN
 - Ultimate moment = 71 kN.m

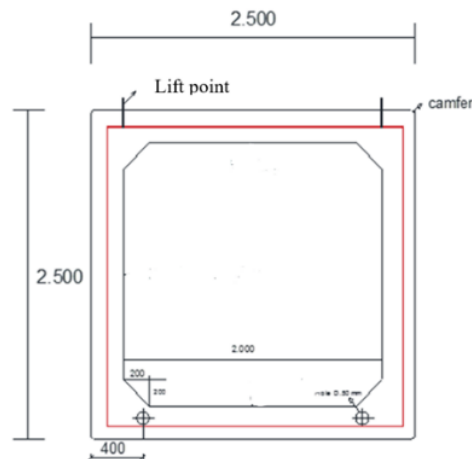

Figure 1. Dimension of box culvert.

2.2. Testing method

The box culvert testing refers to ASTM C293-02 standard test method for flexural strength of concrete (using simple beam with center-point loading) [5] and SNI 1725 2016 [6]. The specimen is placed normally on the strong floor as shown in Figure 2. Two LVDTs are mounted on each side and top wall, and one LVDT (Linear Variable Displacement Transducer) on the bottom wall to measure deflection at these points. The specimen was loaded using a hydraulic jack with a speed of 0.01 mm/sec. The load from the hydraulic jack is then distributed to the specimen using a distributed beam. Bearing pads are placed on the underside of the culvert box and under the distributed beam to avoid localizing stress at that location.



Figure 2. Setup testing.

The load is measured using a load cell with a capacity of 500 kN. To facilitate identification of initial cracks, several strain gauges are mounted on the tensile side of the concrete. In addition, one strain gauge is also mounted on the compression zone of the box culvert (under load cell) to measure the maximum compressive strain on the concrete. The location of LVDT and strain gauge mounted are shown in Figure 3.

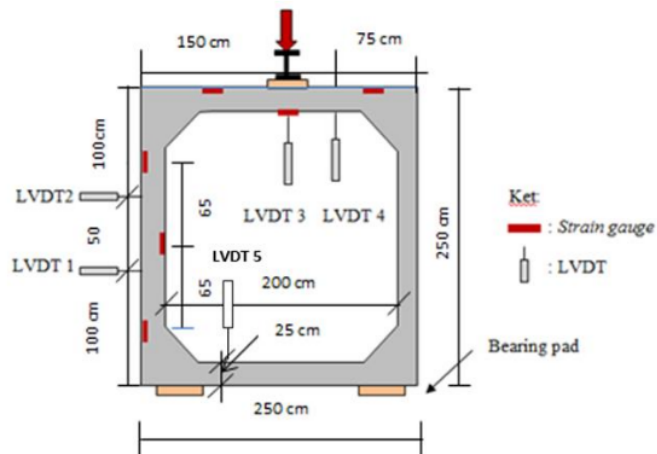

Figure 3. Location of LVDT and strain gauge.

3. Results and discussion

The testing was done on 2 box culvert specimens namely BC-1 and BC-2. Loading is given in 2 stages, stage I until the initial crack occurs and stage II until it passes the ultimate load design.

3.1. Load-deflection relationship

Figure 4 shows the load-deflection relationship in BC-1 and BC-2. The deflection shown in the picture is the deflection in LVDT3 whose position is under the loading point. From the design calculation, the initial cracking time (P_{crack}) is 76.8 kN and the ultimate load (P_{ult}) is 227.2 kN. From Figure 4 it is found that both specimens have the same deflection load behavior. The initial crack occurred at a load of 102 kN and 119.7 kN on BC-1 and BC-2, respectively. This is indicated by the change in stiffness as shown in Figure 5. The load at the initial crack of the two specimens is greater than the design load of 76.8 kN. This shows the initial flexural strength of the culvert box meets the design requirements.

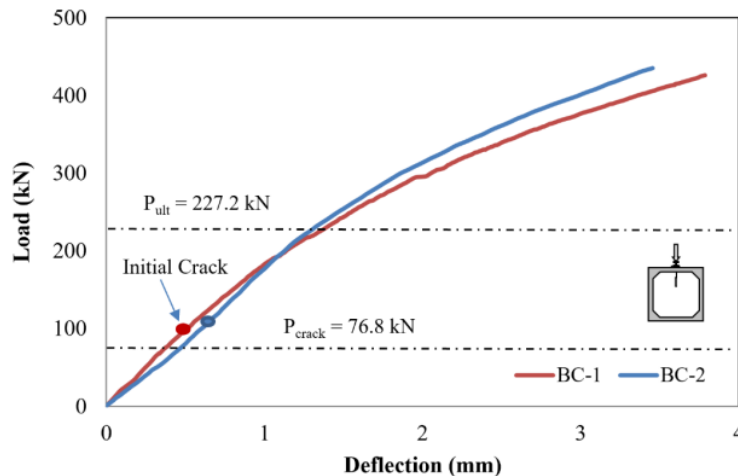

Figure 4. Load-deflection at upper wall.

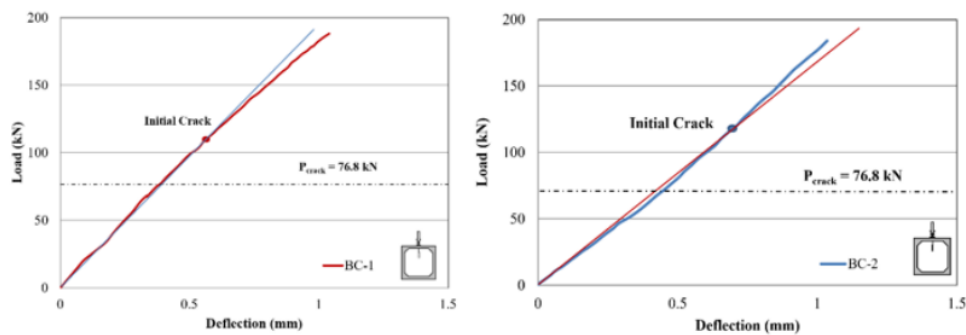

Figure 5. Initial crack of BC-1 and BC-2.

The maximum load shown in Figure 4 is the load when the loading test is stopped at 420 kN, because the capacity of the load cell used is limited to 500 kN, where both specimens have not yet reached the ultimate load. At maximum load, deflection in BC-1 and BC-2 was 3.78 mm and 3.34 mm, respectively. Although it has not yet reached the ultimate load, the maximum load carried by both specimens has exceeded the theoretical ultimate load of 227.2 kN. Then both box culvert met the design flexural strength requirements.

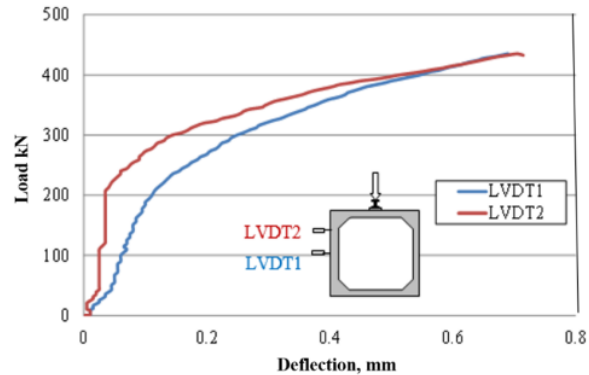

Figure 6. Load-deflection at side wall.

Beside the upper wall, LVDT is also mounted on the side wall, which aims to determine deflection due to axial load. As a representative, the deflection load relationship on the BC-2 sidewall is shown in Figure 6. Deflection of LVDT-1 and LVDT-2 on the sidewall is 0.69 mm and 0.72 mm.

3.2. Crack pattern on the maximum load test

Visually, the initial crack at BC-1 occurred at a load of 179.6 kN, and BC-2 at a load of 172.6 kN. When the load is increased, cracks propagate along the upper wall of the culvert box. After that, in the left and right walls of the box culvert, cracks also began to appear as shown in Figure 7. In the left and right wall the crack occurred at a load of 179.6 kN for BC-1 and 172.6 kN for BC-2.



Figure 7. Crack pattern.

4. Conclusion

Based on the results and discussion, it can be concluded that both specimens BC-1 and BC-2 (box culvert type 2000 x 2000 x 1000 cm) declare to meet the requirements of design and can be used in the railway project in South Sulawesi. The maximum load carried by both specimens has exceeded the theoretical ultimate load of 227.2 kN.

Acknowledgments

A big thanks to the members of the Strengthening and Structural Engineering Research Lab for their help and cooperation during testing

References

- [1] Galih B 2015 *Pembangunan Fisik Jalur Kereta Trans Sulawesi Dimulai Tahun Ini* retrived from: Kompas.com <https://regional.kompas.com/read/2015/01/13/03085361/PembangunanFisikJalurKeretaTransSulawesiDimulaiTahunIni>
- [2] M T Indonesian 2018 *Annual Report of the Directorate General of Railways in 2018*
- [3] Umum D P *Standar Gorong-Gorong Persegi Beton Bertulang (Box Culvert) Type Double* Direktorat Bina Program Jalan Direktorat Bina Marga
- [4] Umum D P *Standar Gorong-Gorong Persegi Beton Bertulang (Box Culvert) Type Single* Direktorat Bina Program Jalan Direktorat Bina Marga
- [5] *ASTM C293-02 standard test method for flexural strength of concrete (using simple beam with center-point loading)*
- [6] Nasional B S 2016 SNI 1725-2016 *Pembebanan Untuk Jembatan*

ORIGINALITY REPORT

3%

SIMILARITY INDEX

%

INTERNET SOURCES

3%

PUBLICATIONS

%

STUDENT PAPERS

PRIMARY SOURCES

1

Alexandra Pop, Andrea Bede, Mircea Cristian Dudescu, Florin Popa, Ioan Ardelean.

"Monitoring the Influence of Aminosilane on Cement Hydration Via Low-field NMR Relaxometry", Applied Magnetic Resonance, 2015

Publication

2%

2

Nurulain Hanida Mohamad Fodzi, M.H. Mohd Hisbany. "Structural Effect of Using Steel Fiber Reinforcement on the Punching Shear of Self-Compacting Fiber Reinforced Concrete (SCFRC) Ribbed Slabs", Materials Science Forum, 2019

Publication

1%

Exclude quotes On

Exclude matches < 5 words

Exclude bibliography On